

## Bitumen & Asphalt



- APV®
- Bran+Luebbe®
- Johnson Pump®
- Lightnin®
- Plenty®

If one believes the proverb, all roads lead to Rome, then the quality of the journey depends on the quality of the road.

Users ask for increasingly better roads, the coatings have to be quieter, safer for the users, ensure better drainage and be more resistant.

At all stages of the process, pumps are used to transfer the bitumen, the emulsions and all the other liquid elements making up their composition.

Ensuring a dominant position in Europe in the transfer of bituminous products, SPX FLOW, with its APV, Bran+Luebbe, Johnson Pump, Lightnin and Plenty brands, has managed to upgrade their ranges of pumps by adapting them to the needs for this sector of activities.

SPX FLOW, Inc. (NYSE:FLOW) is a leading manufacturer of innovative flow technologies, many of which help define the industry standard in the market segments they serve.

From its headquarters in Charlotte, North Carolina, it operates a sales and support network, centers of manufacturing excellence, and advanced engineering facilities, throughout the world. Its cutting-edge flow components and process equipment portfolio includes a wide range of pumps, valves, heat exchangers, mixers, homogenizers, separators, filters, UHT, and drying technology that meet many application needs. Its expert engineering capability also makes it a premium supplier of customized solutions and complete, turn-key packages to meet the most exacting of installation demands.

## Gasketed heat exchanger for moderate Viscosities and low fouling tendency

- Compact, easy to open, extendable
- Highly efficient heat transfer
- Application as cooler and heater
- Relatively low Price per m<sup>2</sup>
- Plate material Stainless Steel
- Rubber gaskets out of Nitrile (NBR), Hydrogenated Nitrile (HNBR) und and Fluor elastomer (FKM)
- Can be used up to 150 °C and 25 bar

### Typical applications:

- Cooling and heating of Bitumen emulsion
- Secondary medium: Thermal oil, Low-Pressure Steam, Water



## Hybrid - Fully welded heat exchanger for higher Viscosities and higher fouling tendency

- Combines benefits of Shell&Tube and Plate heat exchanger
- Larger channel size on bitumen side
- No elastomer gaskets
- Panel can be dismantled for Hydro-Jet cleaning
- Application as cooler and heater
- Plate material Stainless Steel
- Can be used up to 350°C and 32bar

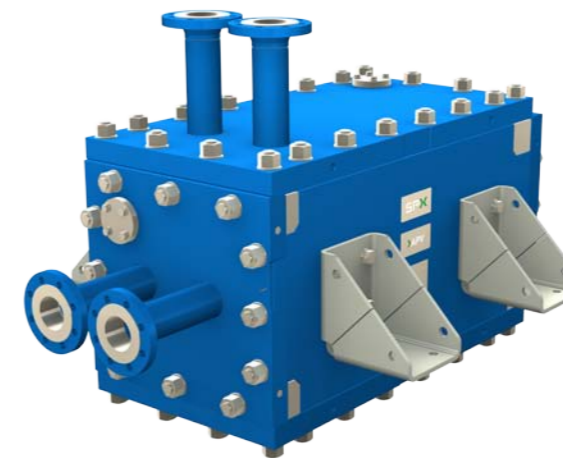

### Typical applications:

- Cooling and heating of Bitumen
- Secondary medium: Thermal oil
- Low-Pressure Steam, Water

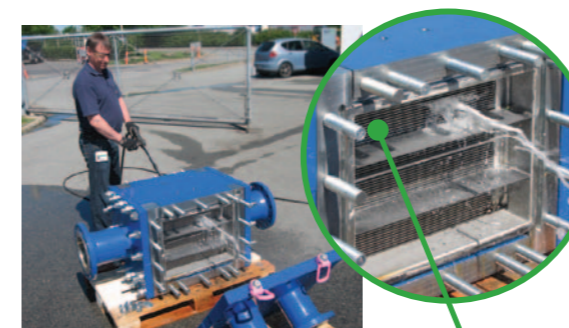

### Openable design

Bolted Hybrid can be opened. The tube-side plate gap can be high-pressure cleaned (TuplaFlow).

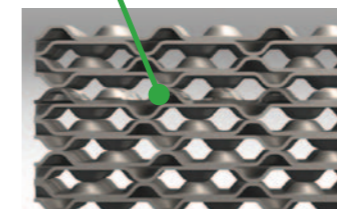

## Typical application

Fully insulated Bitumen cooler type APV Hybrid in a modern coating system for rooftop membranes at Halle/Saale.



Thermal oil is used for cooling. To allow proper distribution over the plate pack, SPX designed the housing with two Bitumen inlets and one center outlet. A multi pass-setup in the heat exchanger ensures stable temperature difference and therefore reduced fouling.

Our customer also uses Hybrid technology to heat bitumen. The allowed pressure drop of <0,5 bar was achieved without losing thermal performance.



## AutoBlend Process Systems - Bitumen Emulsions Production

Bitumen emulsions are used for road surface maintenance.

The emulsion components (bitumen, water, additives and emulsifiers) are taken directly from their storage tanks.

**Type:** manually controlled metering station  
**Capacity:** 12000 l/h

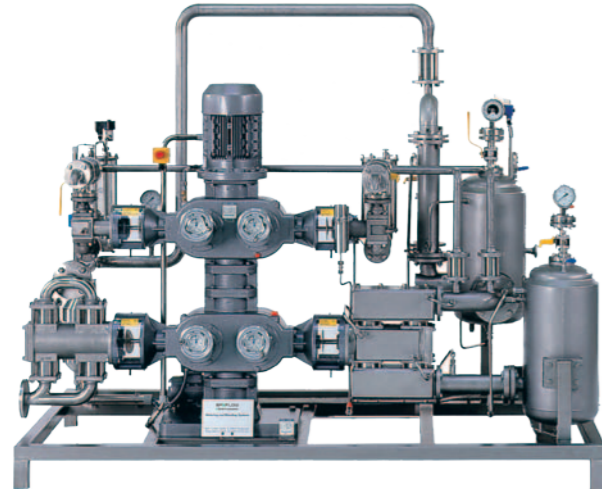

The precise metering of each component ensures constant high quality when the mixture passes through the colloid mill to form the emulsion.

**Advantages:**

- High capacity
- Constant product quality
- Cost savings by direct connection to storage tanks

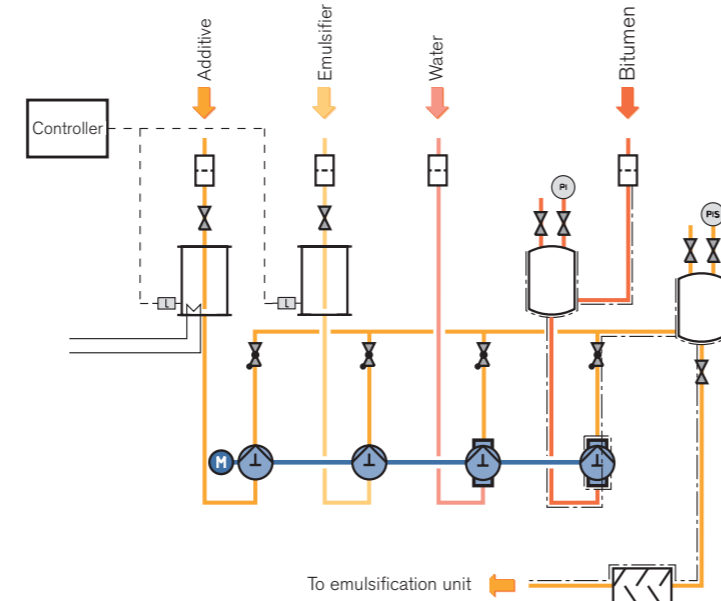

**Components**

- 2 vertically combined metering pumps with manual stroke adjustment, 4 plunger pump heads (2 double-acting)
- 2 air vessels
- 1 static mixer
- Heating jacket for 2 pump heads and 1 suction-side pipe
- 4 in-line filters

## Complete Range of Pumps:

meeting all needs of an emulsion plant: amines, emulsion, bitumen, fluxant, acidic water ...

**Internal gear pumps from our TopGear range**



- Pumps with high flow rate accuracy and broad capacity range
- Heating of the pump with two separate steam, or oil heating jackets
- Electrical heating with optimal temperature regulation from SPX FLOW Johnson Pump optional
- Wear-resistant pump construction for Bitumen with abrasive fillers
- Applicable for high pressure and temperature: 16 bar and 300°C (230 psi and 572°F)

**Technical data:**

- 12 sizes with nominal port diameter from 25mm to 200mm
- Maximum flow 260 m³/h
- Maximum differential pressure 16 bar
- Maximum temperature 300°C
- Maximum viscosity 80,000 mPas



Hydraulic motor drive

**Centrifugal pumps according to EN733**

Pumps for thermal oil, hot water and bitumen emulsion /pure bitumen up to a viscosity of 250 mPas



Centrifugal pump for thermal oil

**Technical data for CombiTherm pump**

- Maximum capacity: 350 m³/Std. (1541 GPM) [50 Hz] - 400 m³/Std. (1761 GPM) [60 Hz]
- Maximum delivery head: 110 m (361 ft) [50 Hz] - 160 m (525 ft) [60 Hz]
- Maximum liquid temperature: Thermal oil 350° C (662° F) Hot water 190° C (374° F)
- Maximum operating pressure: 16 bar (232 psi)
- Maximum speed: 3600 rpm

## Typical product applications



**WATER PROOFING**

- Pump construction designed to transfer minerals contained in the bitumen
- High pressure and temperature acceptable: 16 bar and 300°C (230 psi and 572°F)



**ROADSPRAYER OR SPREADER**

- Constant and non pulsating flow allowing coating at a constant angle
- Large range of speeds
- Electric heating of the pump (optional)
- Additional pump for heating fluid option
- Accessory pump for heating fluid



**EMULSION PLANT**

- Complete range of pumps meeting all needs of an emulsion plant: amines, emulsion, bitumen, fluxant, acidic water, ...
- Care of the emulsion's texture, no product degradation
- Repeatability of the dosing



**COATED ASPHALT PLANT**

- Pumps offering a high degree of accuracy in proportioning
- Large range of flow acceptable
- Electric heating of the pump (optional)



**BINDER STOCK**

- Highly reliable robust pumps
- Low maintenance is required
- Heating of the pump by 2 separate jackets, each thermostatically controlled for optimum result



**SERVICE**

- Uncomplicated design
- Back-pull out design for ease of maintenance
- Strong shafts and maximized bearings for longer life

## Lightnin Mixers take the heat and the pressure



Lightnin 70 Series  
with double mechanical seal

Further downstream in your refinery of chemical works, you may process your Bitumen further.

The Lightnin 70 Series mixers, and other mixers in our range, have the strength and reliability to perform the expected process and to withstand high temperatures and high pressures.

### 70 Series Technical Data:

- 0.75kw to 200kw (2500kw with other Lightnin ranges!)
- 9rpm to 255 rpm, 50 & 60 Hz
- Standard range of Single and Double mechanical seals up to 22Barg and 350°C
- High capacity bearings with 100,000Hrs L10 Bearing Life
- High AGMA gear and bearing service factors

In addition to our high capacity gear drives, we have our full range of Lightnin Impeller technology.



A510  
Low Viscosity



A320  
Gas Handling & High Viscosity



A620  
Very High Viscosity

Each of our impeller can be constructed in Steel, Stainless Steel, Duplex, and other high alloys and Titanium.

We tailor our solution and selections so you get the most out of your process.

## Plenty Mixers for your Bitumen processes.



Plenty Fixed Angle Belt Drive Mixers installed on a heated tank

For more than 60 years Plenty Mixers have been established in the Bitumen processing industries.

Our global product line and manufacturing footprint enable SPX FLOW to meet the local demands for Bitumen processors around the world.

Our leading impeller technology produces high flow rates and minimizes power consumption and blend times. You get the required flow for temperature homogeneity throughout the tank; that ensures your product is as you require it.

Higher viscosities are no problem; each of our drives can be fitted with a range of impellers, so we can select the size that best suits your requirements and process variability.

Standard selections are available specifically for use with Bitumen/Asphalt/Tar production. The options include:

- High temperature capacity sealing, up to 300°C
- Heating jacket around the seal and tank shut off to ensure the bitumen remains fluid
- Heating jacket can be fed from your utilities with Steam, Hot Oil or Electrical tracing
- Correct selection of gasket materials to endure life at elevated temperatures
- High temperature paint systems are applied providing environmental protection as the machine experiences temperature cycles

As standard you get the Plenty Shut-off System that enables routine maintenance of the shaft bearings and the mechanical seal without the need to drain the tank.

Our shut off system is not affected by high temperatures due to its solid single piece shaft construction and because it does not rely on any elastomers to perform this critical function.

The Shut-off incorporates a safety check-valve so you can be assured the shut-off is secure – it is simply solidly reliable.

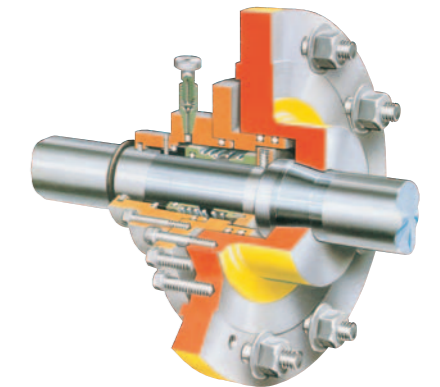

## Typical product applications



### WATER PROOFING

- Pump construction designed to transfer minerals contained in the bitumen
- High pressure and temperature acceptable: 16 bar and 300°C (230 psi and 572°F)



### ROADSPRAYER OR SPREADER

- Constant and non pulsating flow allowing coating at a constant angle
- Large range of speeds
- Electric heating of the pump (optional)
- Additional pump for heating fluid option
- Accessory pump for heating fluid



### EMULSION PLANT

- Complete range of pumps meeting all needs of an emulsion plant: amines, emulsion, bitumen, fluxant, acidic water, ...
- Care of the emulsion's texture, no product degradation
- Repeatability of the dosing



### COATED ASPHALT PLANT

- Pumps offering a high degree of accuracy in proportioning
- Large range of flow acceptable
- Electric heating of the pump (optional)



### BINDER STOCK

- Highly reliable robust pumps
- Low maintenance is required
- Heating of the pump by 2 separate jackets, each thermostatically controlled for optimum result



### SERVICE

- Uncomplicated design
- Back-pull out design for ease of maintenance
- Strong shafts and maximized bearings for longer life



## Global locations

### SPX FLOW TECHNOLOGY

Ironstone Way  
Brixworth, Northants, NN6 9UD  
United Kingdom  
Phone: +44 (0) 1604 880751  
Fax: +44 (0) 1604 880145  
E-Mail: [ftbrixworthsales@spxflow.com](mailto:ftbrixworthsales@spxflow.com)

### SPX FLOW, INC

Building A  
Compass House, Manor Royal  
Crawley, West Sussex, RH10 9PY  
Phone: +44 (0) 161 249 11 70  
E-Mail: [lightnin@spxflow.com](mailto:lightnin@spxflow.com)

### SPX FLOW, INC

1st Floor Ocean House,  
Towers Business Park  
Didsbury, Manchester, M20 2LY  
Phone: +44 (0) 161 249 11 70  
E-Mail: [lightnin@spxflow.com](mailto:lightnin@spxflow.com)

### SPX FLOW TECHNOLOGY (APV)

Nordager 2  
6000 Kolding  
Telefon: +49 (0) 5731 80 80  
Fax: +49 (0) 5731 14 00

For other sales locations please visit us at [www.spxflow.com](http://www.spxflow.com).

### SPX FLOW TECHNOLOGY NORDERSTEDT GMBH

Werkstraße 4  
D-22844 Norderstedt  
Phone: +49 (0) 40 - 522 02 -0  
Fax: +49 (0) 40 - 522 02 -444  
E-Mail: [branluebbe@spxflow.com](mailto:branluebbe@spxflow.com)

SPX FLOW reserves the right to incorporate our latest design and material changes without notice or obligations.

Design features, materials of construction and dimensional data, as described in this bulletin, are provided for your information only and should not be relied upon unless confirmed in writing. Please contact your local sales representative for product availability in your region. For more information visit [www.spxflow.com](http://www.spxflow.com).